





Lubinus SP II

Anatomically Adapted Cemented Hip System

CE 0482

Explanation of Pictograms			
	Manufacturer		Item number
	Material number		Product fulfills the essential requirements of the Medical Device Directive 93/42/EEC

Lubinus SP II

Anatomically Adapted Cemented Hip System

Surgical Technique

- 02 Preoperative Planning
- 05 Surgical Approaches
- 06 Surgical Technique

Implants

- 12 SP II Prosthesis Stems
- 14 SP II Prosthesis Stems XL with long neck

Instruments

- 16 Instruments for SP II Prosthesis Stems, Overview
- 17 Instrument Tray
- 18 Set of Rasp Stems

Additional Instruments

- 19 Handle for Rasp Stems - Coupling of the rasp
- 19 Coloured Plastic Trial Heads
- 20 Femoral Reamers

Accessories

- 26 Instructions for Cleaning and Maintenance
- 26 X-ray Templates

27 **Literature**

28 **Indications/Contraindications**

Important Information

Preoperative Planning

Preoperative planning is conducive towards optimal surgical outcomes by ensuring the most appropriate implants are selected for the patient. The key objectives involved are the correct positioning of the central rotational point of the hip, correct leg length and finally preservation or restoration of sufficient soft tissue tension by avoiding medialisation of the femur.

Achieving anatomically appropriate CCD or neck angle and head-neck length are of paramount importance. The Lubinus SP II System offers CCD angles 117°, 126° and 135° and femoral heads with up to four head-neck lengths affording the surgeon great flexibility.

Planning should ideally be based on two X-rays: an AP film of the pelvis and a mediolateral X-ray of the hip in question. When performing the pelvic X-ray it is important to ensure that:

1. Both femurs are shown in their entirety.
2. The femurs are straight and parallel and, if possible, internally rotated approximately 5° in that position.
3. Key landmarks needed for planning are visible: the inferior margins of the obturator foramen and of the acetabular teardrop.

When evaluating the X-rays, it is important to factor in any magnification incurred. Two factors are decisive:

1) Focal distance

Focal spot X-ray tube | ←x→ | Film cassette
 A focal distance of 100 cm gives magnification of about 10%.

2) Object film distance

Femoral axis | ←x→ | Film cassette

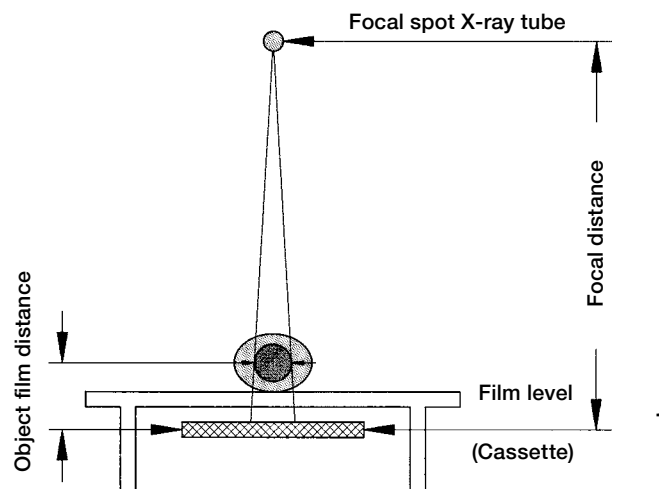

Practical steps

First, geometrical measurements are taken on the basis of the pelvic radiograph. This can be done on the X-ray directly (Fig. 2), but it is better to trace the skeletal contours onto tracing paper (Fig. 3).

A horizontal reference line is drawn along the inferior margins of the obturator foramen, followed by a vertical reference line along the sacral crest, ideally passing through the center of the pubic symphysis.

From these two lines, the center of rotation, difference in leg length, left/right femoral distance, distance between the left/right muscle T lever arms, etc. are defined and marked on the tracing paper.

This provides an overview and landmarks for orientation during surgery, e.g. transfer of dimensional reference to the bone. It must always be remembered that the measurements on the radiograph include a magnification effect that must be allowed for if the measurements are transferred to bone. If the magnification is 10%, measurements taken from the radiograph must be divided by 1.1. So, for example, 60 mm apparent \div 1.1 = 54.5 mm actual measurement. The same applies for other magnifications: e.g. at 15% magnification a 60 mm apparent measurement gives 60 mm \div 1.15 = 52.2 mm actual measurement.

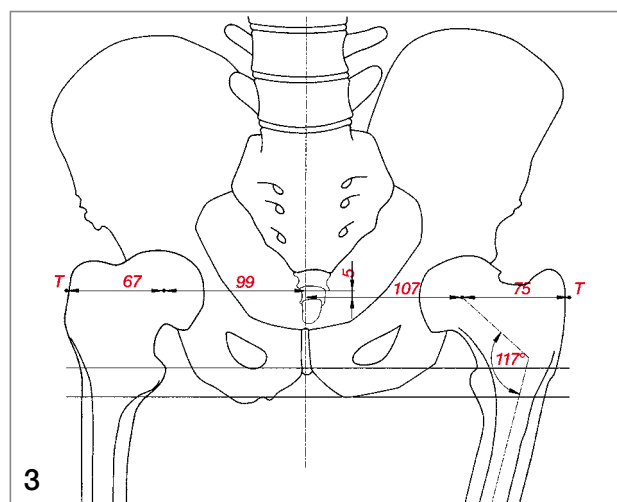
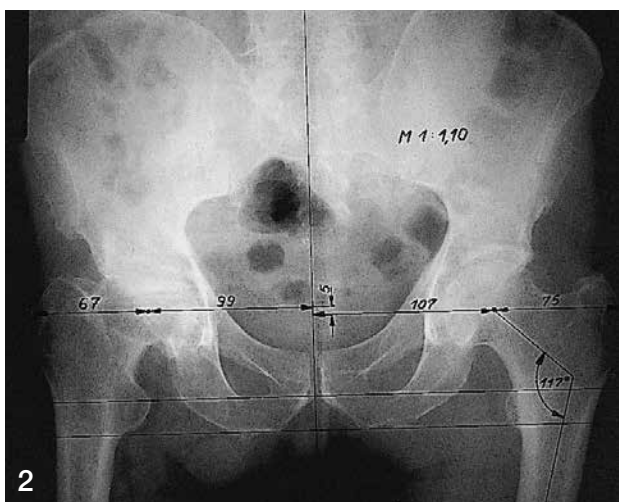

Once the dimensions have been entered, the templates are used to select the best implant components for the particular case. The template is positioned on the radiograph such that the center of rotation coincides with the anatomical center of rotation as determined in the drawing. The implant components selected should correct any anatomical insufficiencies derived from the measurements.

In addition to pelvic radiograph, the mediolateral radiograph is used to determine the stem shape and size of the femoral prosthesis as seen from the lateral view.

The planned result becomes clearer when the transparent sheet with the outlined skeletal contours, measurements, and sketched-in position of the acetabular cup is placed on top of the radiograph and adjusted so that the femur in the radiograph is in the desired outcome position in relation to the drawing of the pelvis. This position is then traced onto the tracing paper, preferably in a different color (Fig. 4).

The differences on the tracing paper, e.g. actual and planned positions of the femur, provide the visual overview required for surgical planning and precise selection of the implant components using the X-ray templates or, if necessary, for custom-design implants (Fig. 5).

Materials required:

1. Tracing paper
2. Transparent ruler, 1:1
3. Transparent protractor
4. Transparent radius/hole template
 \varnothing 24 to 58 mm, in 2 mm increments

Note:

Preoperative planning may be time-consuming but it provides intraoperative guidance and can enhance the final result.

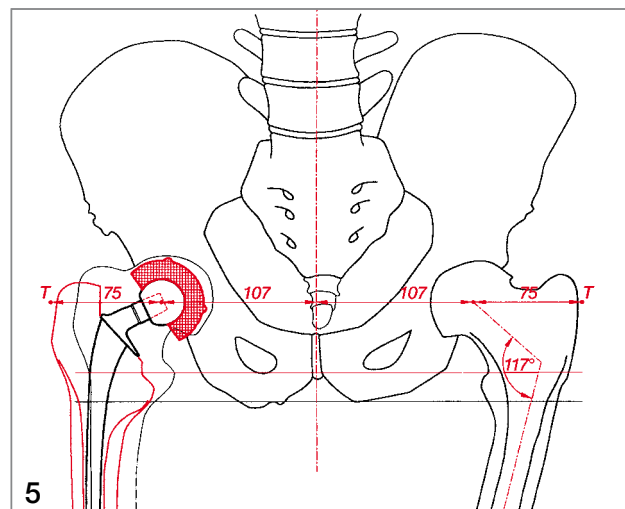
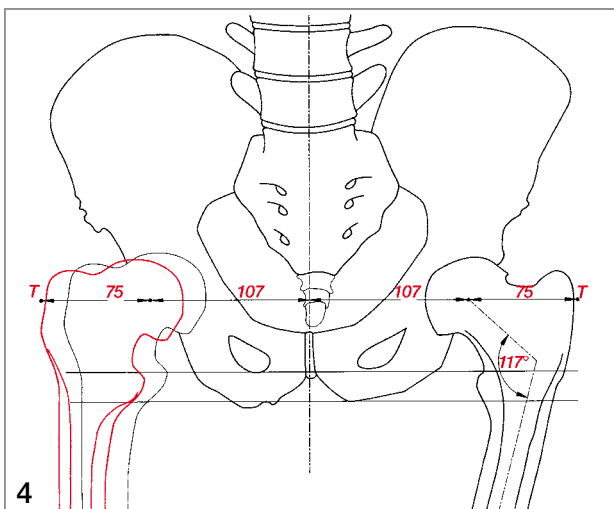

Surgical Approaches

The choice of the approach depends on the surgeon's experience and his/her decision based on the individual situation.

The following approaches are usual:

- antero-lateral - **Watson Jones** (Fig. A)
- direct lateral - **Hardinge** (Fig. B)
- postero-lateral - **Moore** (Fig. C)

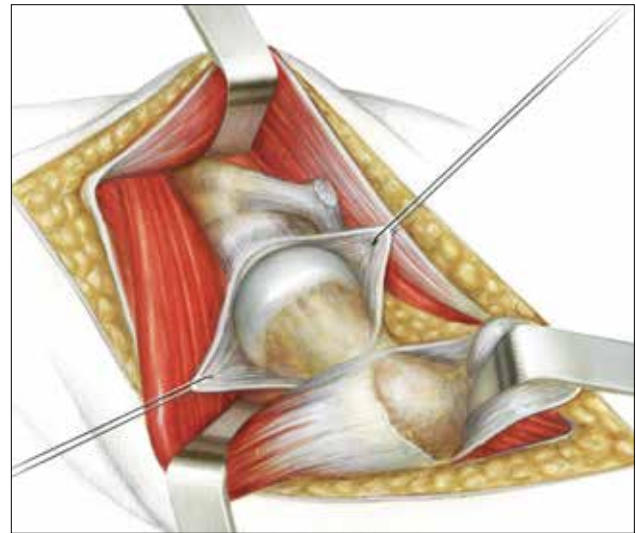

Fig. A: **Watson Jones**

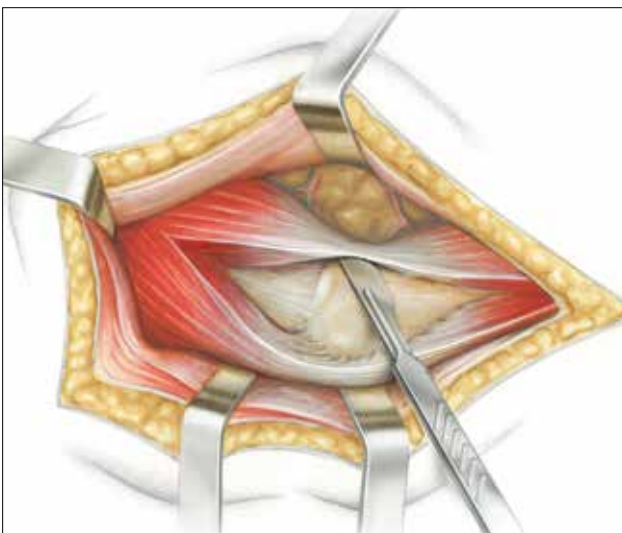

Fig. B: **Hardinge**

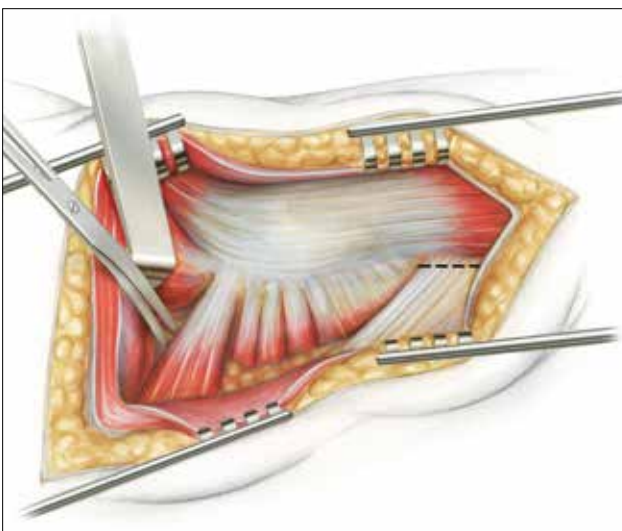
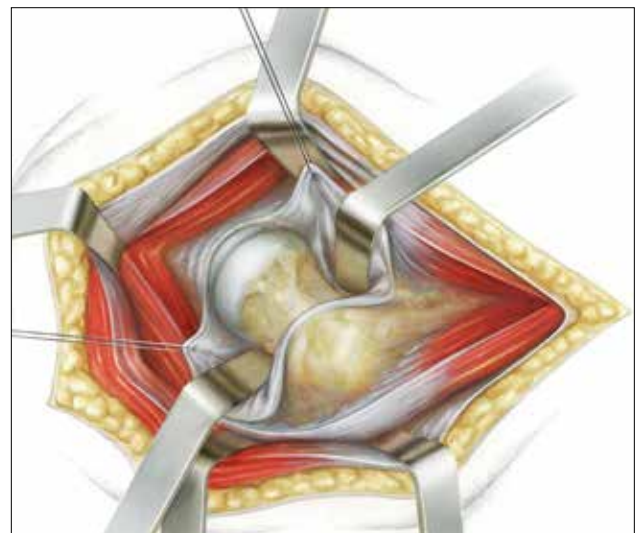
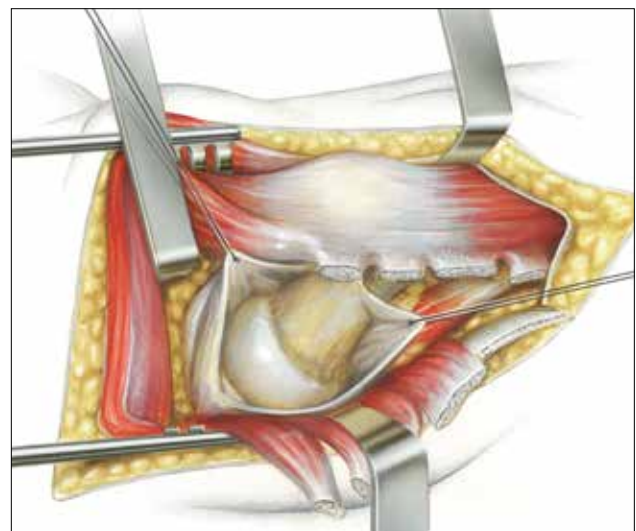

Fig. C: **Moore**



The following illustrations show a posterior approach.

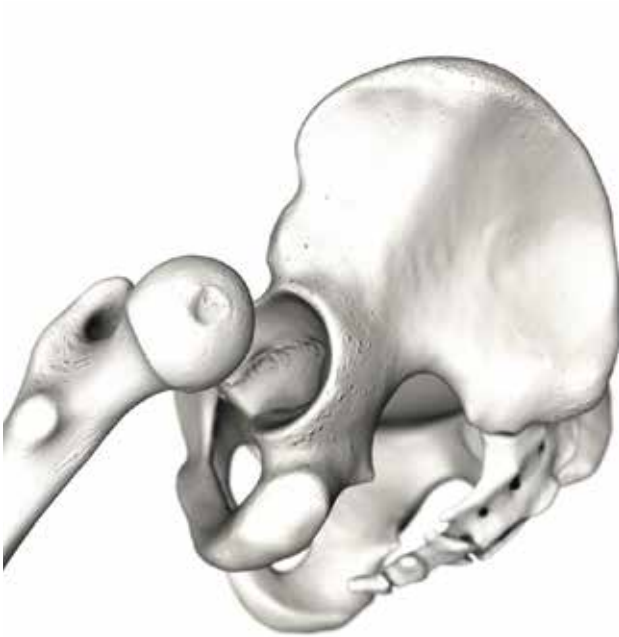

Fig. 1

The hip is dislocated in the usual way. The standard osteotomy plane is normally at 45° to the axis of the femoral stem.

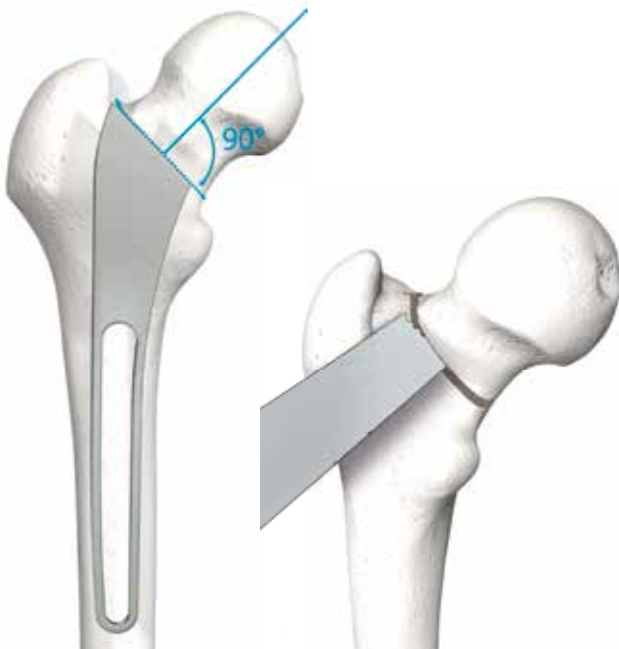

Fig. 2

Resection of the femoral head according to preoperative planning.

A comparison between bone situation and Resection Guide helps to decide on the resection level. Sparing resection is advisable to allow for additional resection or reaming using the calcar reamer if necessary. The resection angle is perpendicular to the axis of the femoral neck.



Fig. 3

Implantation of the acetabular cup

The acetabular cup is usually prepared before the stem.



Fig. 4

The medullary cavity is opened with a Box Chisel. This should be done as far laterally as possible to avoid varus positioning of the stem. The femoral canal is opened with the Femoral Canal Opener, having its entrance point in the fossa piriformis groove.

When using a SP II Long Prosthesis Stem the medullary canal has to be prepared with a reamer of corresponding length. In order to ensure a consistent cement application, the diameter of the reamer has to be larger than the tip of the prosthesis.

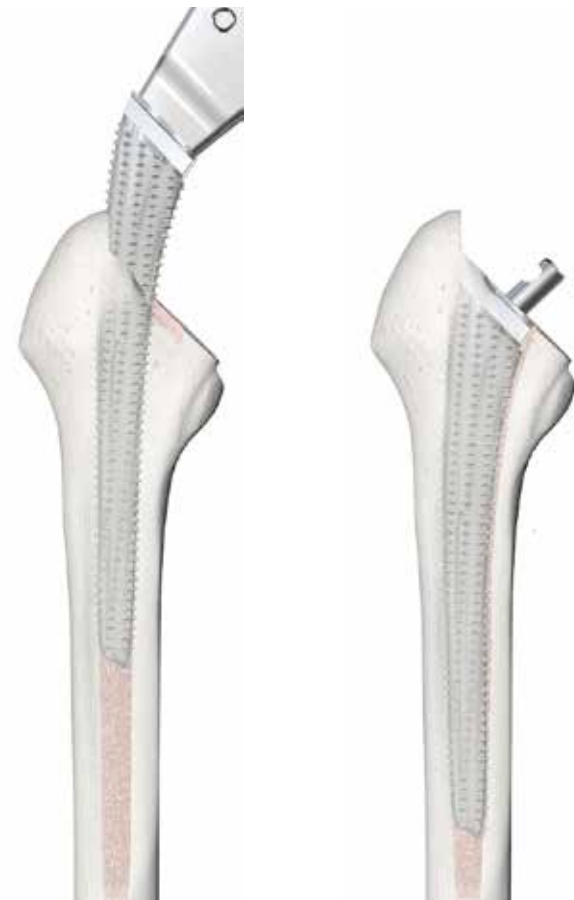
**Fig. 5**

The Rasp Stem is inserted with coupled Rasp Handle.

Due to the anatomical form of the rasps the anteversion usually adjusts itself automatically when they are driven in. The femoral canal is prepared with rasps of increasing size until the planned size is reached.

Note:

In order to widen the proximal lateral part the rasp can be run up and down a couple of times. Thus giving more space for the cement in this area.

The size of the rasp corresponds roughly with the implants (Rasp has an oversize of 0,75 mm comparing to the Implant).

In order to create a cement mantle of about 2-3mm the implanted stem shall be one size smaller than the rasp last used. (e.g. rasp stem R3 = prosthesis stem R2).

**Fig. 6**

The rasp is then left in situ. The rasp stem sits slightly lower than the lowest point of the resection level.

Fig. 7

The Calcar Reamer is now used to create plane parallel seat on the proximal femur to allow precise seating of the collar.

Attention:

To prevent the reamer from being damaged it must be pushed as far as possible caudally on the guide pin before starting to ream.



Fig. 8

Trial reduction is carried out with the final size of rasp in situ. The handle is removed and the Trial Neck Segment selected in preoperative planning (right/left, CCD angle), is placed on the rasp. The different Trial Heads are then used to check for optimal offset and correct leg length and to test whether stability is adequate. The range of movement is also checked to avoid impingement of bone and implant and rule out any instability.



Fig. 9

After trial reduction, the Trial Head and Neck are removed by hand and the rasp is removed with the rasp handle.



Fig. 10

The medullary space is blocked a few centimeters below the planned position of the tip of the femoral stem using either a bone plug or a Medullary Plug. After cement application, the SP II stem is introduced into the femoral cavity as far as possible by using the Insertion Forceps.

Note!

The SP II stem provides inbuilt anatomical antetorsion. Further correction of anteversion, as done with straight stems, is to be avoided.



Fig. 11

The SP II Stem is driven into its final position using the Impactor. While the cement hardens, the stem is pressed firmly into the cement bed with the tip of the Impactor positioned in the hemispherical depression at the lateral collar, thus avoiding transmission of the surgeon's movements to the stem.

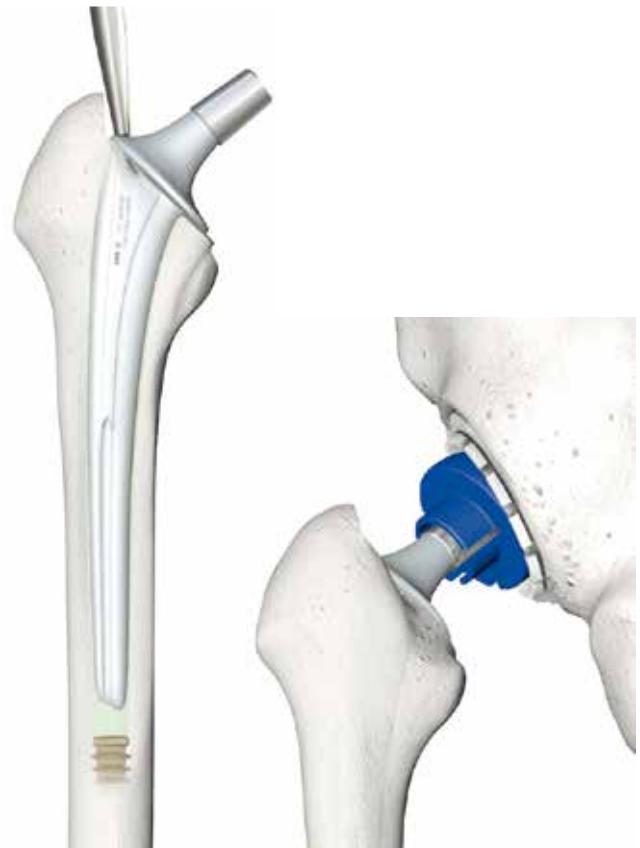

Fig. 12

To be on the safe side, a final trial run is performed using the coloured plastic Trial Heads.

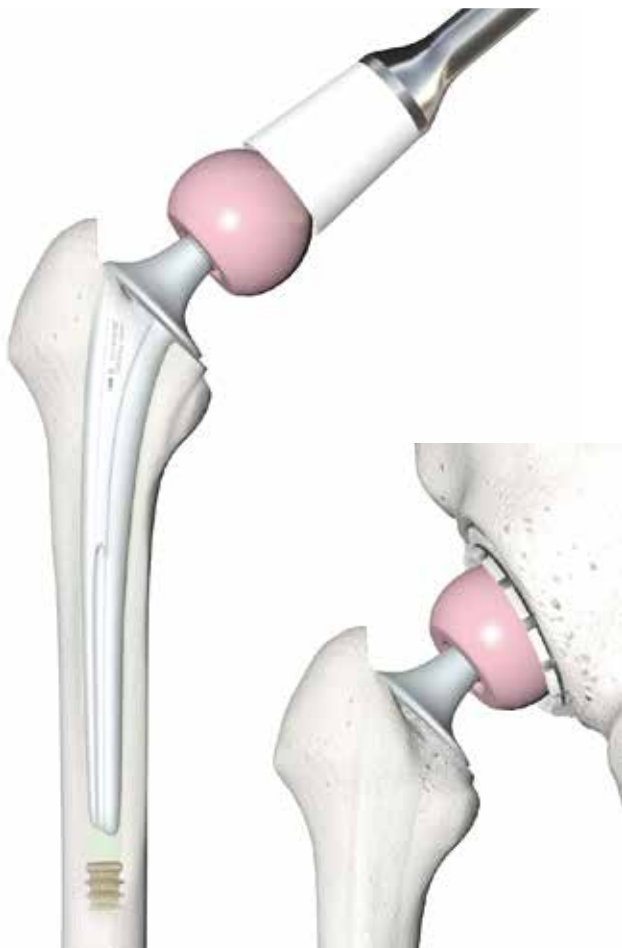

Fig.13

The final Femoral Head is placed on the carefully cleaned taper of the stem and fixed with a light tap on the impactor.

Fig. 14

The **Lubinus SP II Stem** in situ.

Once the joint surfaces have been cleaned the joint is reduced with the final implant components.

The wound is closed in layers.

SP II Prosthesis Stems

MAT: CoCrMo

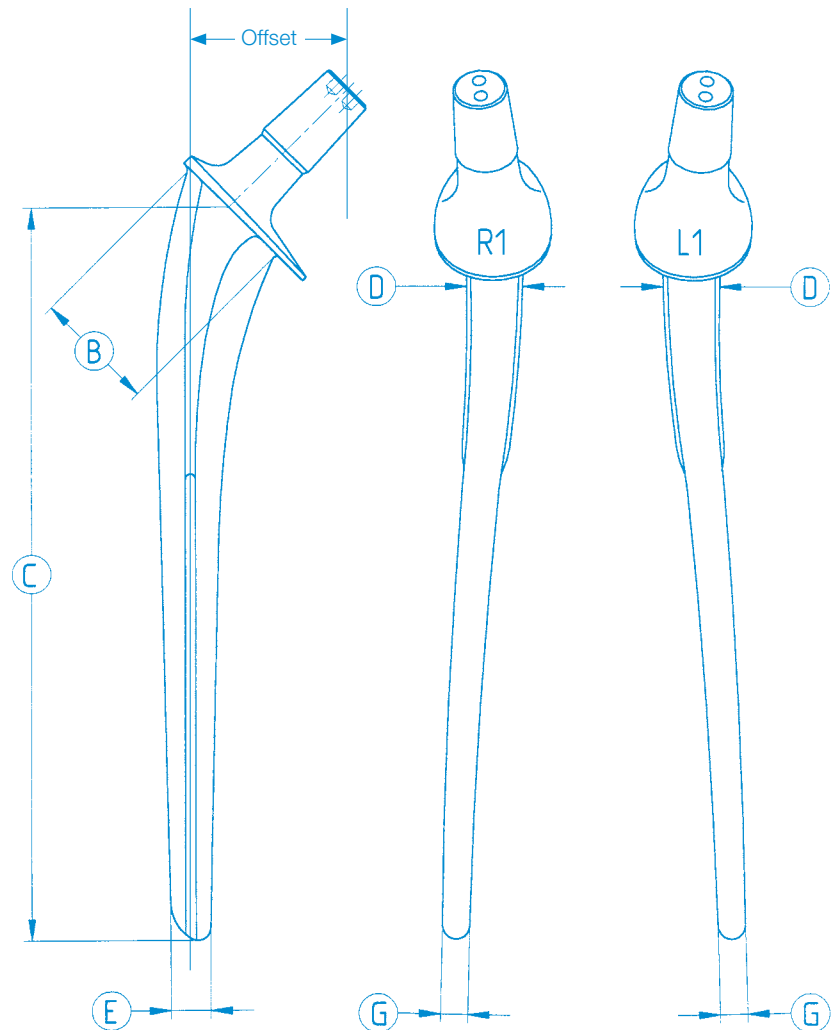
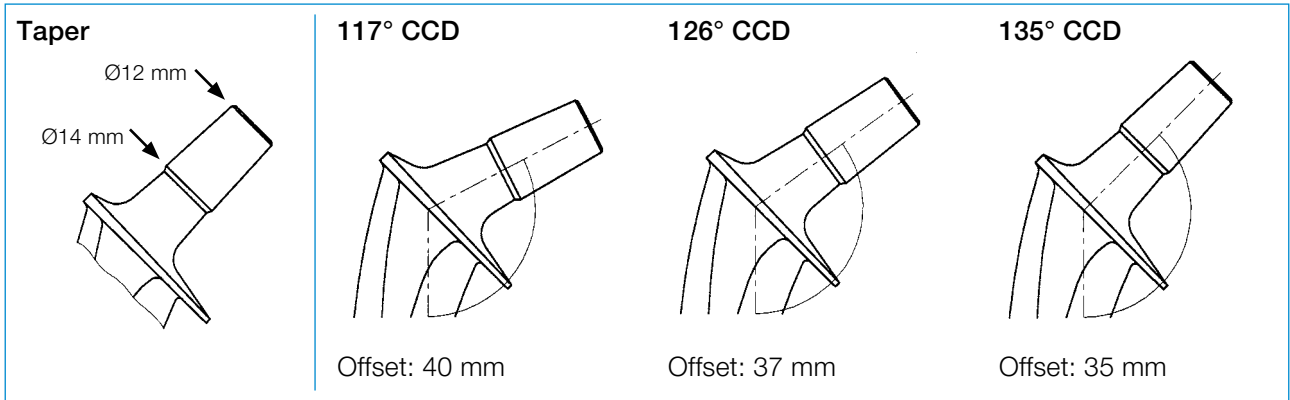

SP II Prosthesis Stems

MAT: CoCrMo

CCD 117° REF	CCD 126° REF	CCD 135° REF	Version	Stem width	ⓑ mm	ⓒ mm	ⓓ mm	ⓔ mm	ⓖ mm	Marking on collar
127-610/17	127-610/26	127-610/35	right	extra narrow	23.5	130	11	8.0	6.0	R 01
127-612/17	127-612/26	127-612/35	right	narrow	25.5	130	13	9.0	6.0	R 1
127-614/17	127-614/26	127-614/35	right	medium	27.5	130	14	10.0	7.5	R 2
127-616/17	127-616/26	127-616/35	right	large	29.5	130	15	11.0	8.0	R 3
127-618/17	127-618/26	127-618/35	right	extra large	31.5	130	16	12.0	8.5	R 4
127-620/17	127-620/26	127-620/35	right	extra large plus	31.5	130	18	12.5	10.0	R 4 A
127-622/17	127-622/26	127-622/35	right	super large	31.5	130	22	13.5	12.0	R 5
127-720/17	127-720/26	127-720/35	right	extra narrow	23.5	150	11	7.5	5.5	R 01
127-722/17	127-722/26	127-722/35	right	narrow	25.5	150	13	8.5	5.5	R 1
127-724/17	127-724/26	127-724/35	right	medium	27.5	150	14	9.5	7.0	R 2
127-726/17	127-726/26	127-726/35	right	large	29.5	150	15	10.5	7.5	R 3
127-728/17	127-728/26	127-728/35	right	extra large	31.5	150	16	11.5	8.0	R 4
127-738/17	127-738/26	127-738/35	right	extra large plus	31.5	150	18	12.0	9.0	R 4 A
127-732/17	127-732/26	127-732/35	right	super large	31.5	150	22	13.0	11.0	R 5
127-710/17	127-710/26	127-710/35	right	extra narrow	23.5	170	11	7.0	5.0	R 01
127-712/17	127-712/26	127-712/35	right	narrow	25.5	170	13	8.0	5.0	R 1
127-714/17	127-714/26	127-714/35	right	medium	27.5	170	14	9.0	6.0	R 2
127-716/17	127-716/26	127-716/35	right	large	29.5	170	15	10.0	6.5	R 3
127-718/17	127-718/26	127-718/35	right	extra large	31.5	170	16	11.0	7.5	R 4
127-736/17	127-736/26	127-736/35	right	extra large plus	31.5	170	18	11.5	8.5	R 4 A
127-730/17	127-730/26	127-730/35	right	super large	31.5	170	22	12.5	10.0	R 5
127-624/17	127-624/26	127-624/35	left	extra narrow	23.5	130	11	8.0	6.0	L 01
127-626/17	127-626/26	127-626/35	left	narrow	25.5	130	13	9.0	6.0	L 1
127-628/17	127-628/26	127-628/35	left	medium	27.5	130	14	10.0	7.5	L 2
127-630/17	127-630/26	127-630/35	left	large	29.5	130	15	11.0	8.0	L 3
127-632/17	127-632/26	127-632/35	left	extra large	31.5	130	16	12.0	8.5	L 4
127-634/17	127-634/26	127-634/35	left	extra large plus	31.5	130	18	12.5	10.0	L 4 A
127-636/17	127-636/26	127-636/35	left	super large	31.5	130	22	13.5	12.0	L 5
127-721/17	127-721/26	127-721/35	left	extra narrow	23.5	150	11	7.5	5.5	L 01
127-723/17	127-723/26	127-723/35	left	narrow	25.5	150	13	8.5	5.5	L 1
127-725/17	127-725/26	127-725/35	left	medium	27.5	150	14	9.5	7.0	L 2
127-727/17	127-727/26	127-727/35	left	large	29.5	150	15	10.5	7.5	L 3
127-729/17	127-729/26	127-729/35	left	extra large	31.5	150	16	11.5	8.0	L 4
127-739/17	127-739/26	127-739/35	left	extra large plus	31.5	150	18	12.0	9.0	L 4 A
127-733/17	127-733/26	127-733/35	left	super large	31.5	150	22	13.0	11.0	L 5
127-711/17	127-711/26	127-711/35	left	extra narrow	23.5	170	11	7.0	5.0	L 01
127-713/17	127-713/26	127-713/35	left	narrow	25.5	170	13	8.0	5.0	L 1
127-715/17	127-715/26	127-715/35	left	medium	27.5	170	14	9.0	6.0	L 2
127-717/17	127-717/26	127-717/35	left	large	29.5	170	15	10.0	6.5	L 3
127-719/17	127-719/26	127-719/35	left	extra large	31.5	170	16	11.0	7.5	L 4
127-737/17	127-737/26	127-737/35	left	extra large plus	31.5	170	18	11.5	8.5	L 4 A
127-731/17	127-731/26	127-731/35	left	super large	31.5	170	22	12.5	10.0	L 5

SP II Prosthesis Stems XL with long neck

MAT: CoCrMo

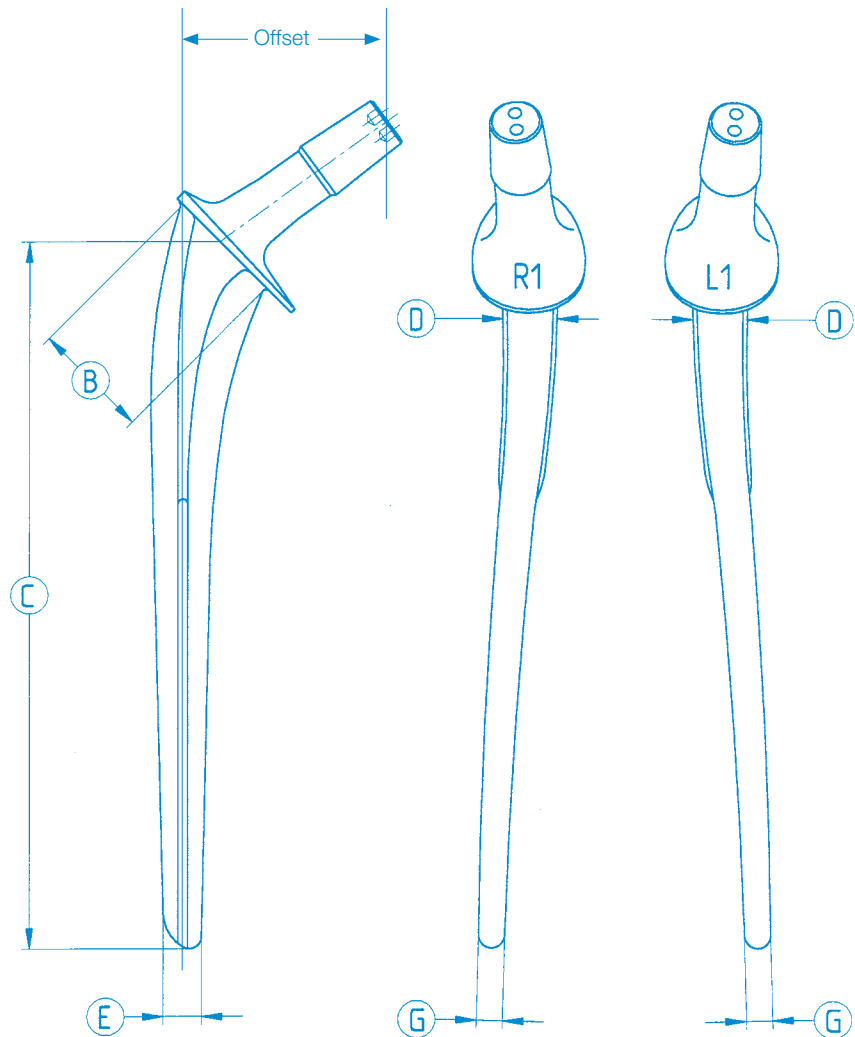
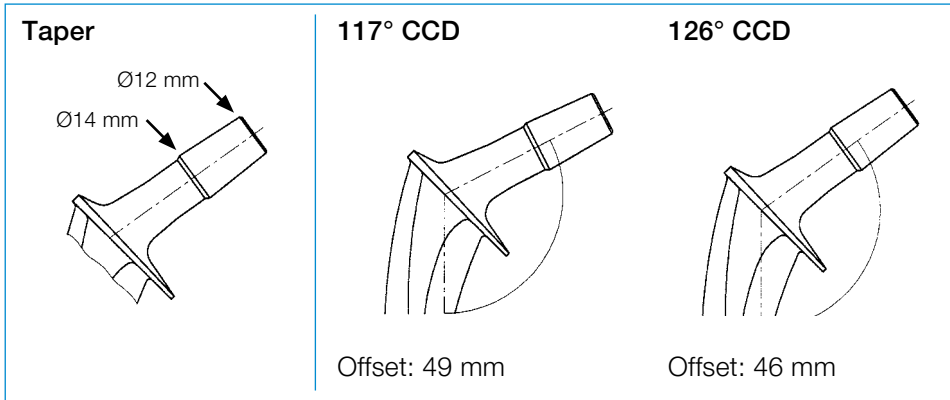

SP II Prosthesis Stems XL with long neck

MAT: CoCrMo

CCD 117° REF	CCD 126° REF	Version	Stem width	ⓑ mm	ⓒ mm	ⓓ mm	ⓔ mm	ⓖ mm	Marking on collar
127-760/17	127-760/26	right	extra narrow	23.5	150	11	7.5	5.5	R 01
127-762/17	127-762/26	right	narrow	25.5	150	13	8.5	5.5	R 1
127-764/17	127-764/26	right	medium	27.5	150	14	9.5	7	R 2
127-766/17	127-766/26	right	large	29.5	150	15	10.5	7.5	R 3
127-768/17	127-768/26	right	extra large	31.5	150	16	11.5	8	R 4
127-770/17	127-770/26	right	extra large plus	31.5	150	18	12	9	R 4 A
127-772/17	127-772/26	right	super large	31.5	150	22	13	11	R 5
127-740/17	127-740/26	right	extra narrow	23.5	170	11	7	5	R 01
127-742/17	127-742/26	right	narrow	25.5	170	13	8	5	R 1
127-744/17	127-744/26	right	medium	27.5	170	14	9	6	R 2
127-746/17	127-746/26	right	large	29.5	170	15	10	6.5	R 3
127-748/17	127-748/26	right	extra large	31.5	170	16	11	7.5	R 4
127-750/17	127-750/26	right	extra large plus	31.5	170	18	11.5	8.5	R 4 A
127-752/17	127-752/26	right	super large	31.5	170	22	12.5	10	R 5
127-761/17	127-761/26	left	extra narrow	23.5	150	11	7.5	5.5	L 01
127-763/17	127-763/26	left	narrow	25.5	150	13	8.5	5.5	L 1
127-765/17	127-765/26	left	medium	27.5	150	14	9.5	7	L 2
127-767/17	127-767/26	left	large	29.5	150	15	10.5	7.5	L 3
127-769/17	127-769/26	left	extra large	31.5	150	16	11.5	8	L 4
127-771/17	127-771/26	left	extra large plus	31.5	150	18	12	9	L 4 A
127-773/17	127-773/26	left	super large	31.5	150	22	13	11	L 5
127-741/17	127-741/26	left	extra narrow	23.5	170	11	7	5	L 01
127-743/17	127-743/26	left	narrow	25.5	170	13	8	5	L 1
127-745/17	127-745/26	left	medium	27.5	170	14	9	6	L 2
127-747/17	127-747/26	left	large	29.5	170	15	10	6.5	L 3
127-749/17	127-749/26	left	extra large	31.5	170	16	11	7.5	L 4
127-751/17	127-751/26	left	extra large plus	31.5	170	18	11.5	8.5	L 4 A
127-753/17	127-753/26	left	super large	31.5	170	22	12.5	10	L 5

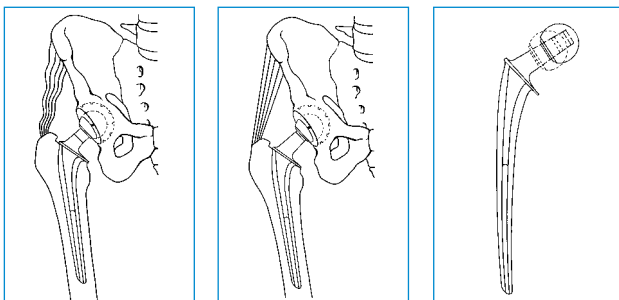

The neck section/taper of SP II XL hip prostheses is 10.5 mm longer than the standard version. When combined with standard prosthesis heads they result in increased head-neck lengths. The XL versions are intended for use in cases where anatomically correct lateralisation of the femur cannot be achieved with the standard SP II stems.

For further information refer to ReOp-Prostheses Endo-Model catalog and SP II Long Prosthesis Stems (LINK 611_Reop_Impl Instr_en).

Instruments for SP II Prostheses

Basic tray

Rasp trays R & L



REF	Description
130-100/15	Basic tray with instruments, complete
130-130/10	Rasp tray , right & left, complete, for 130 mm stems
130-150/10	Rasp tray , right & left, complete, for 150 mm stems
130-170/10	Rasp tray , right & left, complete, for 170 mm stems

130-100/15 Instrument Tray, complete

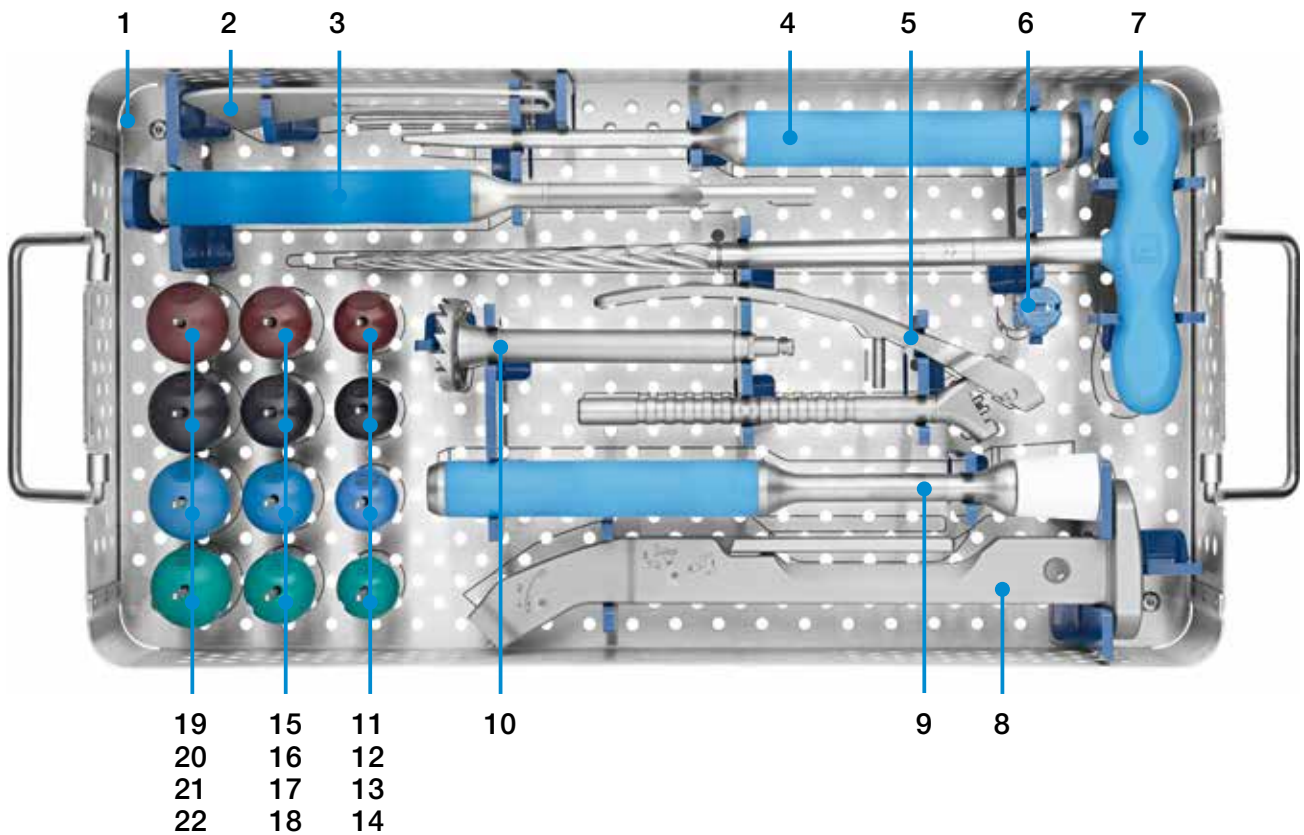

1	130-100/10	Instrument Tray , only, for basic instrument set
2	130-614	Resection Guide , 160 mm
3	130-616	Box chisel , 290 mm
4	130-613	Impactor , 296 mm
5	131-830/03	Insertion Forceps , 200 mm
6	131-830/04	Taper Cap , exchangeable
7	130-617	Femoral Canal Opener , 365 mm
8	130-394/01	Handle for rasp stems and bone compressors, 285 mm
9	130-610/01	Driver for prosthesis heads , with exchangeable plastic head, 280 mm
10	130-407/02B	Calcar reamer with CoCr inner cylinder, Hudson-Fitting , Ø 40 mm, 150 mm
		Adapter, optional:
	130-407/02D	with AO Fitting
11	175-928/14	Trial heads , X-ray positive, Taper 12/14, Ø 28 mm, brown, extra long
12	175-928/13	Trial heads , X-ray positive, Taper 12/14, Ø 28 mm, black, long
13	175-928/12	Trial heads , X-ray positive, Taper 12/14, Ø 28 mm, blue, medium
14	175-928/11	Trial heads , X-ray positive, Taper 12/14, Ø 28 mm, green, short
15	175-932/14	Trial heads , X-ray positive, Taper 12/14, Ø 32 mm, brown, extra long
16	175-932/13	Trial heads , X-ray positive, Taper 12/14, Ø 32 mm, black, long
17	175-932/12	Trial heads , X-ray positive, Taper 12/14, Ø 32 mm, blue, medium
18	175-932/11	Trial heads , X-ray positive, Taper 12/14, Ø 32 mm, green, short
19	175-936/14	Trial heads , X-ray positive, Taper 12/14, Ø 36 mm, brown, extra long
20	175-936/13	Trial heads , X-ray positive, Taper 12/14, Ø 36 mm, black, long
21	175-936/12	Trial heads , X-ray positive, Taper 12/14, Ø 36 mm, blue, medium
22	175-936/11	Trial heads , X-ray positive, Taper 12/14, Ø 36 mm, green, short

Sets of Rasp stems

130-130/10, 130-150/10, 130-170/10

LEFT

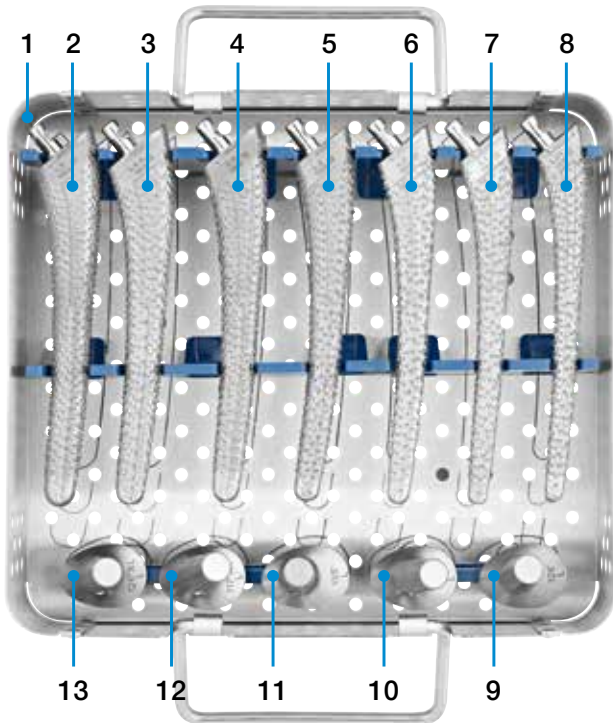

RIGHT

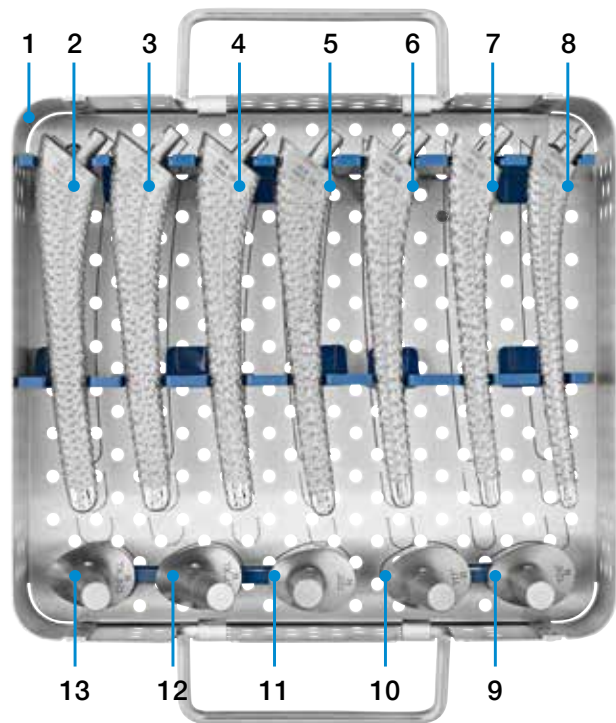

1	130-100/30	Tray, empty, left
2	130-551/07	Rasp stem, 130 mm, left
	130-553/07	Rasp stem, 150 mm, left
	130-555/07	Rasp stem, 170 mm, left
3	130-551/06	Rasp stem, 130 mm, left
	130-553/06	Rasp stem, 150 mm, left
	130-555/06	Rasp stem, 170 mm, left
4	130-551/05	Rasp stem, 130 mm, left
	130-553/05	Rasp stem, 150 mm, left
	130-555/05	Rasp stem, 170 mm, left
5	130-551/04	Rasp stem, 130 mm, left
	130-553/04	Rasp stem, 150 mm, left
	130-555/04	Rasp stem, 170 mm, left
6	130-551/03	Rasp stem, 130 mm, left
	130-553/03	Rasp stem, 150 mm, left
	130-555/03	Rasp stem, 170 mm, left
7	130-551/02	Rasp stem, 130 mm, left
	130-553/02	Rasp stem, 150 mm, left
	130-555/02	Rasp stem, 170 mm, left
8	130-551/01	Rasp stem, 130 mm, left
	130-553/01	Rasp stem, 150 mm, left
	130-555/01	Rasp stem, 170 mm, left
9	131-531/26	Trial neck section, 126°, green
10	131-531/17	Trial neck section, 117°, green
11	131-531/35	Trial neck section, 135°, green
12	131-529/17	Trial neck section, 117°, green, XL
13	131-529/26	Trial neck section, 126°, green, XL

1	130-100/20	Tray, empty, right
2	130-550/07	Rasp stem, 130 mm, right
	130-552/07	Rasp stem, 150 mm, right
	130-554/07	Rasp stem, 170 mm, right
3	130-550/06	Rasp stem, 130 mm, right
	130-552/06	Rasp stem, 150 mm, right
	130-554/06	Rasp stem, 170 mm, right
4	130-550/05	Rasp stem, 130 mm, right
	130-552/05	Rasp stem, 150 mm, right
	130-554/05	Rasp stem, 170 mm, right
5	130-550/04	Rasp stem, 130 mm, right
	130-552/04	Rasp stem, 150 mm, right
	130-554/04	Rasp stem, 170 mm, right
6	130-550/03	Rasp stem, 130 mm, right
	130-552/03	Rasp stem, 150 mm, right
	130-554/03	Rasp stem, 170 mm, right
7	130-550/02	Rasp stem, 130 mm, right
	130-552/02	Rasp stem, 150 mm, right
	130-554/02	Rasp stem, 170 mm, right
8	130-550/01	Rasp stem, 130 mm, right
	130-552/01	Rasp stem, 150 mm, right
	130-554/01	Rasp stem, 170 mm, right
9	131-530/26	Trial neck section, 126°, red
10	131-530/17	Trial neck section, 117°, red
11	131-530/35	Trial neck section, 135°, red
12	131-528/17	Trial neck section, 117°, red, XL
13	131-528/26	Trial neck section, 126°, red, XL

Coupling of the rasp

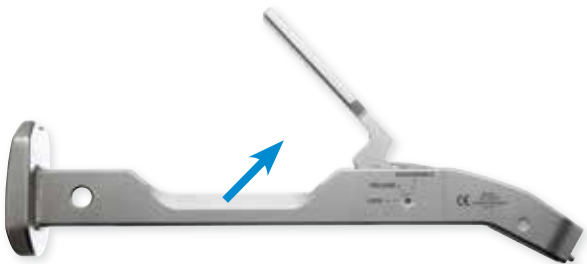

1
To couple rasp and handle, the catch is retracted fully (arrow, left). Then, the rasp fitting is inserted into the mount on the front of the handle (arrow, right, Fig. 1).



2
To secure the connection between rasp and handle, the catch is pushed forwards (arrow) (Fig. 2).



3
To disengage open the handle (arrow) (Fig. 3). The handle can then be detached from the rasp.

Additional Instruments



Coloured Plastic Trial Heads, Taper 12/14 mm

REF	Ø (mm)	Neck length	Head neck length (mm)	Colour	Qty.
131-924/01	24	short	-3.5	green	1
131-924/02	24	medium	0.0	blue	1
175-940/11	40	short	-4.0	green	1
175-940/12	40	medium	0.0	blue	1
175-940/13	40	long	+4.0	black	1
175-940/14	40	extra long	+8.0	brown	1

130-250/00 Femoral reamers, flexible for medullary canal opening

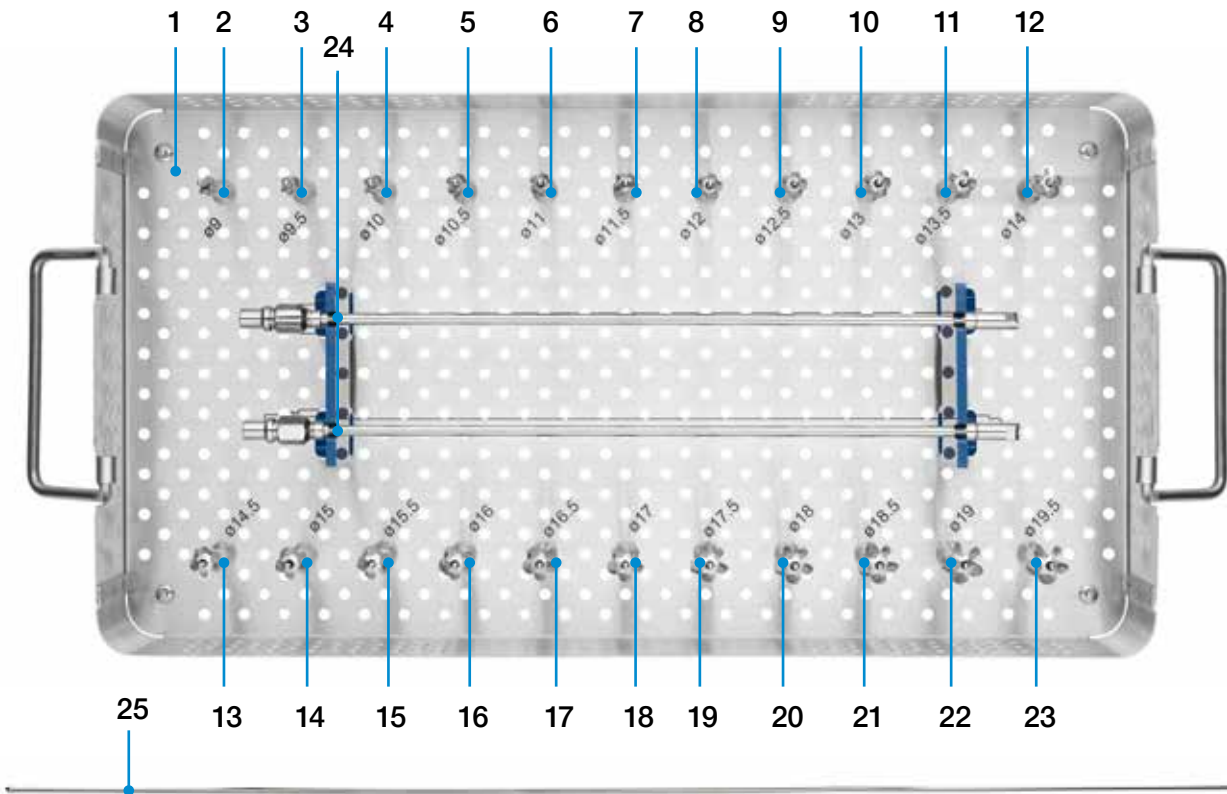

	REF		Ø (mm)
1	130-251/00	Tray, only, sterilizable, with product illustrations	
2	130-370/01	Reamer Head	9.0
3	130-370/02	Reamer Head	9.5
4	130-370/03	Reamer Head	10.0
5	130-370/04	Reamer Head	10.5
6	130-370/05	Reamer Head	11.0
7	130-370/06	Reamer Head	11.5
8	130-370/07	Reamer Head	12.0
9	130-370/08	Reamer Head	12.5
10	130-370/09	Reamer Head	13.0
11	130-370/10	Reamer Head	13.5
12	130-370/11	Reamer Head	14.0
13	130-370/12	Reamer Head	14.5
14	130-370/13	Reamer Head	15.0
15	130-370/14	Reamer Head	15.5
16	130-370/15	Reamer Head	16.0
17	130-370/16	Reamer Head	16.5
18	130-370/17	Reamer Head	17.0
19	130-370/18	Reamer Head	17.5
20	130-370/19	Reamer Head	18.0
21	130-370/20	Reamer Head	18.5
22	130-370/21	Reamer Head	19.0
23	130-370/22	Reamer Head	19.5
24	130-376B	Flexible Reamer Shaft, Length 350 mm, 2 pcs	
25	130-376/01	Guide Wire, Length 670 mm, Ø 3.0 mm	

130-394/02 Universal Handle for rasp stems and compressors, angled, right

130-394/03 Universal Handle for rasp stems and compressors, angled, left



Hohmann Retractor

REF	Version	Width	Length
130-100	small	10 mm	240 mm
130-105	medium	22 mm	260 mm
130-110	wide	43 mm	240 mm



Dederich Bone Lever with hollow handle
 The design makes the instrument comfortable to hold over an extended period.

REF	Version	Width	Length
15-1032	medium	18 mm	150 mm
15-1033	wide	43 mm	195 mm



Soft Tissue Retractors
 with retrograde bend

REF	Version	Width	Length
66-3470	small	22 mm	325 mm
66-3472	wide	43 mm	325 mm



130-120 Bone Hook
 1 prong, with T-handle, 210 mm



130-150 Femoral Head Extractor
 270 mm



130-114 LINK Bone Retractor
 with fenestrated handle, 30 mm wide, 260 mm



130-155

LINK Femoral Head Grasping Forceps

285 mm



The forceps have triangular jaws, each with three sharp spikes situated at the corners, at the ends of the arms. The jaws are movable and snugly fit the femoral head contours. The handle has supports

for the surgeon's hand. The fold-in lock means the instrument can be used with or without the locking mechanism. It is robust, and copes well with heavy tasks.

68-1475

Bircher Meniscus/Cartilage Clamp

with teeth in jaws, 200 mm



130-139 Cartilage Scissors

angled, 250 mm



50-2562 Cartilage Scissors

straight, 220 mm



50-2564 Cartilage Scissors

curved, 220 mm



130-160

Lubinus Steinmann Pin

with impact head and extraction hole
 Ø 5 mm, 185 mm



For use as a self-retaining retractor, one pin is driven into the ischium and another one is driven in approximately 2 cm above the cranial edge of the acetabulum.

For removal, another pin is slid through the hole in the impact head and the Steinmann Pin is then easily removed with a rotating motion.



130-618 Osteotome, 263 mm



130-610/02 Plastic replacement head for driver of prosthesis heads

130-164 Slotted driver for handle (for rasp stems) and stem extractor, 310 mm



130-163/60 Mallet
 Ø 28 mm, 270 mm, 600 Gramm



130-163/90 Mallet
 Ø 37 mm, 270 mm, 900 Gramm

Plastic replacement head for mallet

REF	for mallet	Ø (mm)	Weight
130-163/61	130-163/60	28	600 g
130-163/91	130-163/90	37	900 g

130-610 Cement packer

Ø 10 mm, 291 mm



Bone Plug Impactor to insert bone plugs into the medullary cavity

REF	Ø (mm)
Unthreaded	
131-200	8
131-202	10
131-204	12
131-206	14
131-208	16
131-210	18
Threaded	
131-220	8
131-222	10
131-224	12
131-226	14
131-228	16
131-230	18



Length 383 mm



Length 400 mm

131-250/26 Inserter for Medullary Plugs, graduated, 355 mm, includes 2 inserter

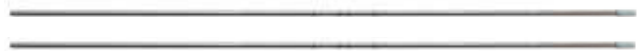

Medullary Plugs, Material: UHMWPE

REF	Ø (mm)
109-130/12	12
109-130/13	13
109-130/14	14
109-130/15	15
109-130/16	16
109-130/17	17
109-130/18	18
109-130/19	19
109-130/20	20



131-250/23 T-Handle for inserter 131-250/26

Instructions for Cleaning and Maintenance

Specific instructions for instruments are available on request: E-mail customer@linkhh.de

X-ray Templates

X-ray templates for Lubinus SP II Prosthesis Stems, standard

Neutral head-neck length, taper 12/14 mm, 110 % actual size

REF	CCD angle	Head-Ø mm	for stem length mm	Set of sheets
131-415/17	117°	28/32	130	7
131-415/26	126°	28/32	130	7
131-415/35	135°	28/32	130	7
131-416/17	117°	36	130	7
131-416/26	126°	36	130	7
131-416/35	135°	36	130	7

X-ray templates for Lubinus SP II Prosthesis Stems, standard

Neutral head-neck length, taper 12/14 mm, 110 % actual size

REF	CCD angle	Head-Ø mm	for stem length mm	Set of sheets
131-417/17	117°	28/32	150/170	7
131-417/26	126°	28/32	150/170	7
131-417/35	135°	28/32	150/170	7
131-418/17	117°	36	150/170	7
131-418/26	126°	36	150/170	7
131-418/35	135°	36	150/170	7

X-ray templates for Lubinus SP II Prosthesis Stems XL

Neutral head-neck length, taper 12/14 mm, 110 % actual size

REF	CCD angle	Head-Ø mm	for stem length mm	Set of sheets
131-419/17	117°	28/32	150/170	7
131-419/26	126°	28/32	150/170	7
131-420/17	117°	36	150/170	7
131-420/26	126°	36	150/170	7

H. Malchau, P. Herberts, P. Söderman, A. Odén

Prognosis of Total Hip Replacement. Update and Validation of Results from the Swedish National Hip Arthroplasty Register 1979-1998 Scientific Exhibition, 67th Annual Meeting of the American Academy of Orthopaedic Surgeons, March 15-19, 2000, Orlando, USA (H105, dt, en, fr, it, sp)

P. Lubinus, W. Klauser

Ein computergestütztes System für die präoperative Planung in der Hüftendoprothetik
Orthop. Praxis 36. Jahrgang 10/2000 (H107)

H. Malchau, P. Herberts, G. Garellick, P. Södermann, T. Eisler

Prognosis of Total Hip Replacement. Update of Results and Risk-Ratio Analysis for Revision and Re-revision from the Swedish National Hip Arthroplasty Register 1979-2000. (H119, dt, en, fr, it, sp)

H. Malchau, P. Herberts, G. Garellick, P. Södermann, T. Eisler

Scientific Exhibition, 69th Annual Meeting of the American Academy of Orthopaedic Surgeons, February 13-17, 2002, Dallas, USA

G. Annaratone, F.M. Surace, P. Salerno, G. Ferrero Regis

Survival analysis of the cemented SP11 stem
J Orthopaed Traumatol 2000; 1:41-45 (H111)

J. Stolk

A Computerized Pre-Clinical Test for Cemented Hip Prostheses based on Finite Element Techniques
Thesis University of Nijmegen, The Netherlands, with summary in Dutch - 192p; 2002

P. Lubinus, W. Klauser, B. Schwantes, R. Eberle

Cemented total hip arthroplasty: the SP-II femoral component
Giornale Italiano di Ortopedia e Traumatologia Vol. XXVIII Fasc. 6, Dicembre 2002 (H124)

LINK NEWS 16 (dt)

Stellenwert der SP11® Modell Lubinus® Hüftprothese im aktualisierten Bericht d. Nationalen Schwedischen Hüft TEP-Registers v. 1979-2002
Waldemar Link GmbH & Co. KG (H125)

J. Stolk, S.A. Maher, N. Verdonshot, P.J. Prendergast, R. Huiskes

Can Finite Element Models Detect Clinically Inferior Cemented Hip Implants
Clinical Orthop. & Related Research No. 409, April 2003 (H126)

LINK NEWS 16 (engl.)

Significance of the Lubinus SP11® Hip Prosthesis in the updated report of the Swedish National Total Hip Arthroplasty Register 1979-2002
Waldemar Link GmbH & Co. KG (H129)

Summary of Annual Report 2002

The Swedish National Hip Arthroplasty Register
Department of Orthopaedics Sahlgrenska University Hospital April 2003 (H131, dt, en, fr, it, sp)

F. Cantani, A. Ensini, A. Leardini, S. Giannini et al.

Migration of Cemented Stem and Restrictor After Total Hip Arthroplasty
T. Journal of Arthroplasty Vol. 20, No. 2, Febr. 2005 (H139)

Summary of Annual Report 2004

The Swedish National Hip Arthroplasty Register
Department of Orthopaedics Sahlgrenska University Hospital May 2005 (H131)

H. Malchau, H. Lindahl, G. Garellick, H. Regner, P. Herberts

Three Hundred and Twenty-one Periprosthetic Femoral Fractures; JBJS USA Vol. 88-A Number 6 June 2006 (H147)

A. G. Enocson, J. Minde, O. Svensson

Socket wall addition device in the treatment of recurrent hip prosthesis dislocation
Acta Orthop. Scand. Vol. 77, No. 1, pp. 87-91 2006 (H148)

Wierer et al.

Radiostereometric migration analysis of the Lubinus SP II hip stem: 59- hips followe for 2 year
Biomed Tech 2013, 58 (4): 333-341 (H177)

Wybren Prins et al.

"Excellent results with the cemented Lubinus SP II 130-mm femoral stem at 10 years of follow-up"
932 hips followed for 5-15 years
Acta Orthopaedica 2014; 85 (3): 276-279

Sebastian Mukka et al.

Substantially higher prevalence of postoperative periprosthetic fractures in octogenarians with hip fractures operated with a cemented, polished tapered stem rather than an anatomic stem"
A prospective cohort study involving 979 hips
Acta Orthopaedica 2016; 87 (6):1

Truike M. Thien et al.

Periprosthetic Femoral Fracture within Two Years After Total Replacement
The Journal of Bone and Joint Surgery, Am. 2014;96:e167(1-7)

Additional Literature

For more information please register for our LINK Media Library (linkorthopaedics.com)

Indications/Contraindications

<p>Indicated indications and contraindications: Lubinus SP II Hip Prosthesis System (all types)</p>
<p>General Indications</p>
<p>Mobility-limiting diseases, fractures or defects which cannot be treated by conservative or osteosynthetic procedures</p>
<p>Indications</p>
<p>Primary and secondary osteoarthritis</p>
<p>Rheumatoid arthritis</p>
<p>Corrections of functional deformities</p>
<p>Avascular necrosis</p>
<p>Femoral neck fractures</p>
<p>Revision after implant loosening dependent on bone mass and quality</p>
<p>Contraindications</p>
<p>Acute and chronic infections, local and systemic insofar as they compromise the successful implantation of a total hip prosthesis (preoperative microbiological analysis recommended)</p>
<p>Allergies to (implant) materials</p>
<p>Insufficient/inadequate bone mass- or quality which prevents a stable anchorage of the prosthesis</p>

Please note:

These indications/contraindications refer to standard cases. The ultimate decision on whether or not an implant is suitable for a patient must be made by the surgeon based on his/her individual analysis and his/her experience.

Please note:

LINK Lubinus SP II Hip Stems can be combined with prostheses heads up to +4mm additional neck length.

Please note the following regarding the use of our implants:

1. Choosing the right implant is very important.

The size and shape of the human bone determine the size and shape of the implant and also limit the load capacity. Implants are not designed to withstand unlimited physical stress. Demands should not exceed normal functional loads.

2. Correct handling of the implant is very important.

Under no circumstances should the shape of a finished implant be altered, as this shortens its life span. Our implants must not be combined with implants from other manufacturers.

The instruments indicated in the Surgical Technique must be used to ensure safe implantation of the components.

3. Implants must not be reused.

Implants are supplied sterile and are intended for single use only. Used implants must not be reused.

4. After-treatment is also very important.

The patient must be informed of the limitations of the implant. The load capacity of an implant cannot compare with that of healthy bone!

5. Unless otherwise indicated, implants are supplied in sterile packaging.

Note the following conditions for storage of packaged implants:

- Avoid extreme or sudden changes in temperature.
- Sterile implants in their original, intact protective packaging may be stored in permanent buildings up until the "Use by" date indicated on the packaging.
- They must not be exposed to frost, dampness or direct sunlight, or mechanical damage.
- Implants may be stored in their original packaging for up to 5 years after the date of manufacture. The "Use by" date is indicated on the product label.
- Do not use an implant if the packaging is damaged.

6. Traceability is important.

Please use the documentation stickers provided to ensure traceability.

7. Further information on the material composition is available on request from the manufacturer.

Follow the instructions for use!

Waldemar Link GmbH & Co. KG, Hamburg

All content in this catalog, including text, pictures and data, is protected by law. Every instance of use, whether in part or in whole and which is not permitted by law, is subject to our prior consent. In particular, this applies to the reproduction, editing, translation, publishing, saving, processing, or passing on of content stored in databases or other electronic media and systems, in any manner or form. The information in the catalogs is solely intended to describe the products and does not constitute a guarantee.

The Surgical Technique described has been written to the best of our knowledge and belief, but it does not relieve the surgeon of his/her responsibility to duly consider the particularities of each individual case.

Products shown in this document may not be available in your country. The product availability is subject to the approval and/or registration regulations of the respective country. Please contact Waldemar Link GmbH & Co. KG if you have questions about the availability of LINK products in your country.

Waldemar Link GmbH & Co. KG and/or other corporate affiliated entities own, use or have applied for the following trademarks in many jurisdictions: LINK, BiMobile, SP II, Modell Lubinus, E-Dur, EndoDur, T.O.P. II, BetaCup, CombiCup PF, CombiCup SC, CombiCup R, MobileLink, C.F.P., LCU, SP-CL, LCP, MIT-H, Endo-Model, Endo-Model SL, MP, MEGASYSTEM-C, GEMINI SL, SPAR-K, LCK, HX, TiCaP, X-LINKed, PorAg, LINK PorEx, BiPorEx, PorEx-Z, TrabecuLink, Tilastan, customLink, RescueSleeve, VACUCAST.

Other trademarks and trade names may be used in this document to refer to either the entities claiming the marks and/or names or their products and are the property of their respective owners.



Waldemar Link GmbH & Co. KG

Barkhausenweg 10 · 22339 Hamburg · Germany

Phone +49 40 53995-0 · info@linkhh.de

www.linkorthopaedics.com

